



Overview of Kepler Series Cameras

Higher Speeds, More Channels, New Sensors

One Giant Leap Forward

Kepler is FLI's new series of cooled cameras, providing higher throughput, more channels, and a variety of new sensors, including scientific CMOS.

Scientific CMOS Cameras

New Kepler releases include the KL400 and KL4040 cameras. They will be followed by the very large area KL6060 camera. Each camera features a high QE, low-noise, high frame-rate cooled sCMOS sensor. The KL400 is one of the most sensitive cameras in existence (1.5 e- read noise, 95% QE). The KL4040 is a high QE front illuminated camera with a generous 52mm imaging diagonal and the game changing KL6060 features a 38MP, 87mm diagonal sensor. The KL400 & KL6060 are available with front or back illuminated sensors.

Higher Speeds

The extremely high bandwidth of Kepler's USB 3.0 and optional QSFP (fiber) interfaces make it possible to push up speeds on sensors already supported by FLI, such as increasing the frame rate of the KAI-29052 interline transfer CCD by a factor of 10.

More Channels

Kepler currently supports up to 35 channel readout, greatly increasing potential throughput, as well as providing support for sensors like the ON Semi KAI-47051 interline transfer CCD.

New Generation EMCCDs

In queue to be added to the Kepler - Interline EMCCDs! Global shutter, intra-scene switchable gain, wide dynamic range and ultra-low read noise. The best of both worlds - ON Semi EMCCDs capture bright and faint objects in one image.

Modularity

The majority of FLI cameras are exported; to minimize shipping costs, Kepler's shutter, fans, and digital board have all been designed to be user-replaceable.



KL400 with Optional 45mm Shutter

Camera Applications:

Orbital Debris Detection
Photocell Inspection
TEM

Software Support

MicroManager
MATLAB
LabVIEW
ASCOS

Kepler cameras include *Pilot Control Software*

PRELIMINARY Specifications

Kepler Model	KL400 FI, KL400 BI	KL4040	KL6060 FI, KL6060 BI
Sensor Type	Front & Back illuminated	Front illuminated	Front & Back illuminated
Resolution	2048 x 2048	4096 x 4096	6144 x 6144
Pixel Size	11 x 11 microns	9 x 9 microns	10 x 10 microns
Imaging Area	22.5 x 22.5 mm	36.9 x 36.9 mm	61.4 x 61.4 mm
Sensor Diagonal	31.9 mm	52.1 mm	86.9 mm
Maximum Frame Rate	48 fps (24 fps HDR)	24 fps (QSFP)	8.4 fps (14 bit)
Read Noise	1.5 e- (FI) / 1.6 e- (BI)	3.7 e-	4.2 e- (14 bit)
Full Well Capacity (e-)	120000 (FI) ; 90000 (BI)	70000 e-	70000 e-
Dynamic Range (HDR)	96 dB (FI) / 93 dB (BI)	86 dB	75 dB
Shutter	Rolling	Rolling; Rolling with Global Reset	Rolling; Rolling with Global Reset
Peak QE	58% (FI) / 95% (BI)	74% (CMT)	72% (FI); 95% (BI)
Cooling	45°C Below Ambient	40°C Below Ambient	40°C Below Ambient
Dark Current @ -20C	0.2 eps (FI); 0.6 eps (BI)	0.15 eps	0.1 eps

Quality. Cooled. Cameras.

Finger Lakes Instrumentation LLC
www.flicamera.com · 1250 Rochester St. · Lima NY 14485 USA · 585-624-3760

©2018 Finger Lakes Instrumentation LLC



KL400 Cooled Scientific CMOS Cameras

The Ultimate in Sensitivity

KL400: 95% Peak QE, 1.6 e- Noise RMS

The Kepler KL400 sCMOS camera represents the first release in a new family of scientific CMOS cameras from Finger Lakes Instrumentation. The KL400 provides ultra-high sensitivity, ultra-low noise with high frame rates, all at a game-changing price to performance ratio.



KL400 with Optional 45mm Shutter
Air & Liquid Cooling

Sensor Type	Front & Back illuminated
Shutter Type	Rolling
Active Pixels	2048 x 2048
Pixel Size (microns)	11 x 11
Effective Area	22.5 x 22.5 mm
Sensor Diagonal	31.9 mm
Full Well Capacity (e-)	120000 (FI) / 90000 (BI)
Frame rate (rolling)	48 fps
	24 fps HDR
Read Noise (rolling HDR) (e-)	1.5 (FI) / 1.6 (BI)
Dynamic Range (HDR)	96 dB (FI) / 93 dB (BI)
Peak QE	58% (FI) / 95% (BI)
Cooling	Air and Liquid ¹
Maximum Cooling (Air)	45°C Below Ambient
Dark Current @ -20C	0.2 eps (FI); 0.6 eps (BI)
Interface	USB 3.0
Interface (Optional)	SFP ²
Data Bit Depth ³	16 bit
Mount	F-mount
Video size	2.0"
Subarray Readout	Yes
Electromechanical Shutter	Optional 45mm
Ex Trigger In	Yes
Ex Trigger Out	Yes

Applications:

Orbital Debris Detection
Photocell Inspection
Forensic Sciences
Super-Resolution Microscopy
Confocal Microscopy
Light Sheet Microscopy
TIRF and GFP

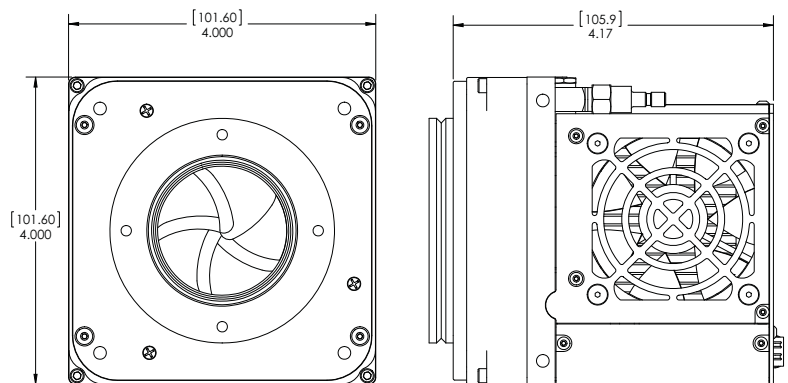
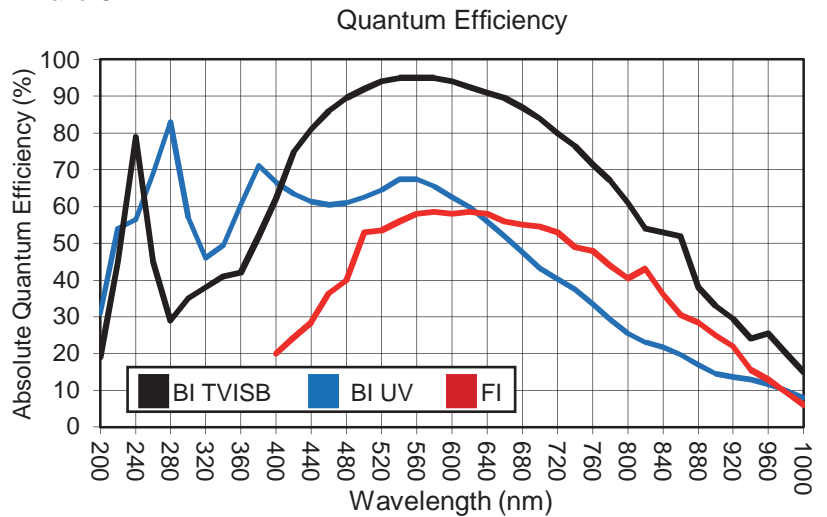

¹ Liquid circulation connectors sold separately

² SFP = Small Form factor Pluggable: high speed fiber optic interface

³ 16-bit data merged from two 12 bit converters

Quality. Cooled. Cameras.

Finger Lakes Instrumentation LLC
www.flicamera.com · 1250 Rochester St. · Lima NY 14485 USA · 585-624-3760

©2018 Finger Lakes Instrumentation LLC



KL4040 Cooled Scientific CMOS Cameras

High Resolution and Low Noise at Video Frame Rate

PRELIMINARY

KL4040: 4K x 4K at 24 fps

The KL4040 scientific CMOS camera has the same pixel size and imaging area as the popular KAF-16803 CCD, but with 1/3 the noise and 40% higher quantum efficiency. Kepler cooled sCMOS cameras provide ultra-high sensitivity, ultra-low noise, and high frame rates, all at game-changing price to performance ratio.

Sensor Type	Front illuminated
Shutter Type	Rolling; Rolling with Global Reset
Active Pixels	4096 x 4096
Pixel Size	9 x 9 microns
Effective Area	36.9 x 36.9 mm
Sensor Diagonal	52.1 mm
Full Well Capacity	70000 electrons
Max. Frame Rate (QSFP)	24 fps
Max. Frame Rate (USB3)	8 fps
Read Noise (rolling)	3.7 e-
Dynamic Range	86 dB
Peak QE	74% (CMT)
Cooling	Air and Liquid ¹
Maximum Cooling (Air)	40°C Below Ambient
Dark Current	0.15 eps at -20C
Interface	USB 3.0
Interface (Optional)	QSFP ²
Data Bit Depth ³	16 bit
Mount	F-mount
Video size	3.3"
Subarray Readout	Yes
Electromechanical Shutter	Optional 65mm
Ex Trigger In	Yes

Camera Applications:
Orbital Debris Detection
Photocell Inspection
TEM



Kepler KL4040

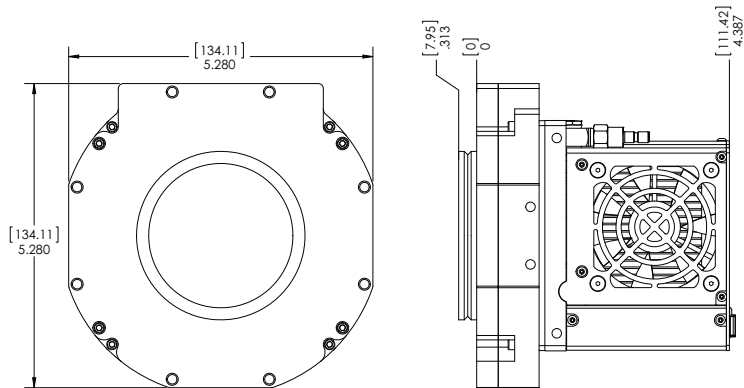
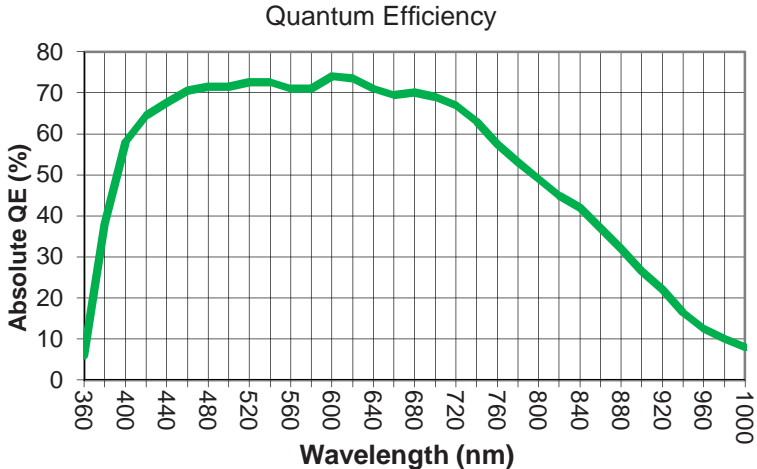

¹ Liquid circulation connectors sold separately

² SFP = Small Form factor Pluggable: high speed fiber optic interface

³ 16-bit data merged from two 12 bit converters

Quality. Cooled. Cameras.

Finger Lakes Instrumentation LLC
www.flicamera.com · 1250 Rochester St. · Lima NY 14485 USA · 585-624-3760

©2018 Finger Lakes Instrumentation LLC



Kepler Cooled Scientific CMOS Cameras

The Ultimate in Sensitivity

PRELIMINARY

KL6060: 95% QE, 4.2 e- Noise, 87mm diagonal

The Kepler KL6060 sCMOS camera represents the first large format scientific CMOS camera from Finger Lakes Instrumentation. The KL6060 provides large imaging area, ultra-high sensitivity, and ultra-low noise. The sensor will be available in front-illuminated and back-illuminated versions.

Gain, Noise, and Full Well Capacity

When gain is set for maximum linear full well (about 4.5e-/ADU), noise is 12e- and full well capacity is about 70ke-. When gain is set for lowest noise (about 0.5 e-/ADU), noise is 4.2e- and full well capacity is about 8ke-.

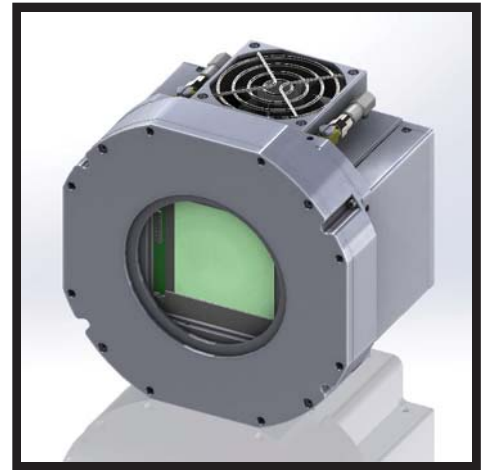

Sensor Type	Front or Back illuminated
Sensor	GPixel GSense6060
Active Pixels	6144 x 6144
Pixel Size (microns)	10 x 10
Imaging Area	61.44 x 61.44 mm
Sensor Diagonal	86.9 mm
Max. Full Well Capacity	70Ke-
Max. Frame Rate (QSFP)	8.4 fps
Max. Frame Rate (USB3)	5 fps
Min. Read Noise (rolling)	4.2 e-
Max. Dynamic Range	75 dB
Peak QE	72% (FI) / 95%(BI)
Cooling	Air and Liquid ¹
Maximum Cooling (Air)	40°C Below Ambient
Dark Current	0.6 eps at -20C
Interface	USB 3.0
Interface (Optional)	QSFP ²
Data Bit Depth	14 bit ³
Mount	Bolt Circle
Subarray Readout	Yes
Electromechanical Shutter	Optional 90mm
Ex Trigger In	Yes
Ex Trigger Out	Yes
Software	FLI

Expected Quantum Efficiency
(Based on KL400 TVISB and KL4040 CMT)

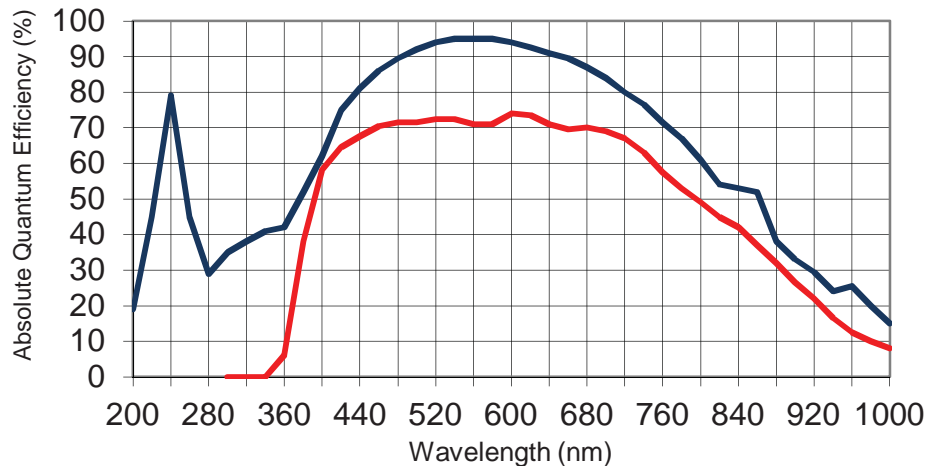

Actual Sensor Size (61mm x 61mm)

Quality. Cooled. Cameras.

Finger Lakes Instrumentation LLC
www.flicamera.com · 1250 Rochester St. · Lima NY 14485 USA · 585-624-3760

©2018 Finger Lakes Instrumentation LLC

¹Liquid circulation adapters sold separately.

²QSFP = Quad Small Form factor Pluggable: high speed fiber optic interface. Required for maximum frame rate.

³Initial release of camera will be 14 bit. Future release will include dual 12 bit HDR support.